

JR1	適応身長	A	B	C	D	E	F	G	H	I	J	K
XS(mm)	161~170	515	364.4	508.5	480	110	70°	73.5°	730	986	70	420
M(mm)	170~180	545.5	381	555.3	530	150	72.5°	73.5°	780	955.3	70	420
JF1	適応身長	A	B	C	D	E	F	G	H	I	J	K
XS(mm)	156~165	530	370.2	539.6	410	110	69.5°	73.5°	730	1043.6	70	450
M(mm)	164~	560	392.3	566.2	455	130	71.5°	73.5°	755	1055.5	70	450

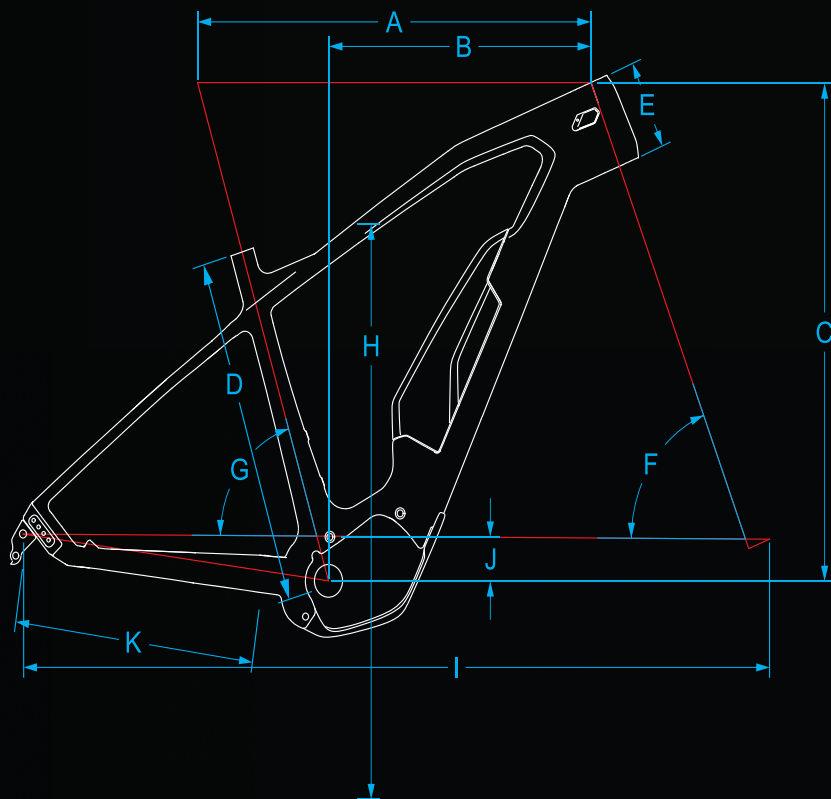

TRS1	適応身長	A	B	C	D	E	F	G	H	I	J	K※
XS(mm)	157~	575	383.2	627.5	394.5	105	51°	73°	764	1107.5	60	458~422

※三段階調整式